

Walmart 4th Wall

Front End Tenant Signage Guidelines

April 2009

Customer**experience**

Introduction

Walmart has been carefully planned to provide quality retail venues for its customers. The purpose of this manual is to assist retail tenants not only in meeting the signage criteria of Walmart, but also to help each tenant communicate an overall image of quality to its customers. These signage guidelines have been developed to ensure appropriate retail identification and uniform graphic applications. Retail tenants within Walmart stores are urged to carefully review these guidelines prior to designing and implementing their signage programs.

Contents

| | |
|----------------------------|----|
| 4th Wall Design | 2 |
| Tenant Sign Panels | 4 |
| Branded Sign Panels | 6 |
| 4th Wall Restrictions | 7 |
| Walmart Services | 8 |
| Clinic Signage | 14 |
| Lowered Ceiling Height | 17 |
| Awnings | 20 |
| Fabrication & Installation | 21 |
| Restroom Signage | 22 |
| Contacts | 23 |

4th Wall Design (New Stores)

The preferred 4th Wall design uses an extended Walmart bulkhead in brand blue. Tenant signage and storefronts are slightly recessed to create a more enclosed and welcoming shopping experience for our customers. The restaurants and merchants lining the front end are important resources to Walmart shoppers, and this new layout provides a more boutique shopping experience in contrast to the large scale of the rest of our store.

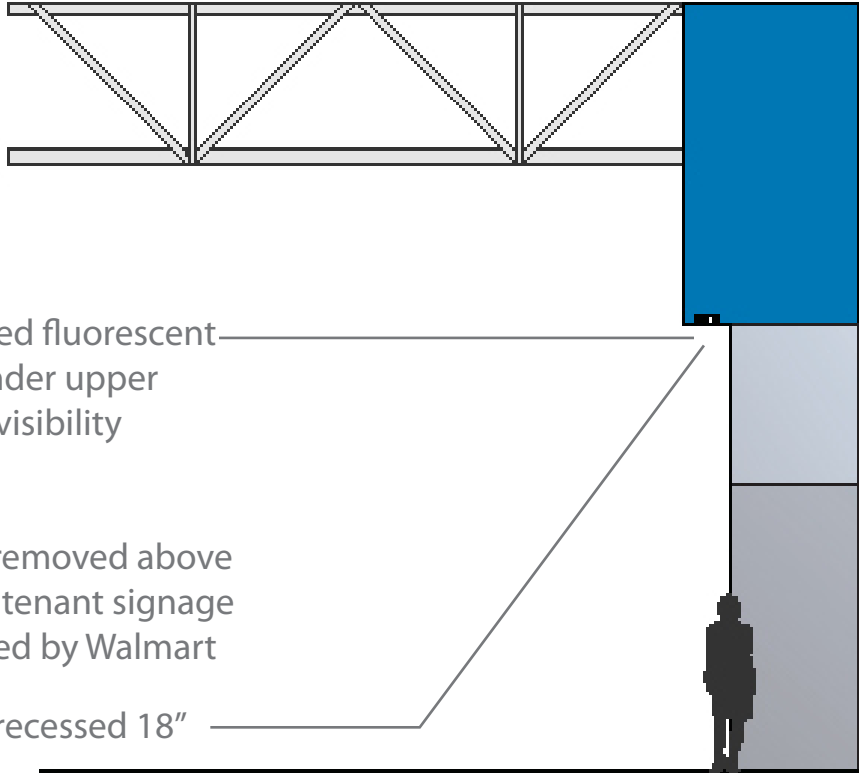

In select stores recessed fluorescent lighting is installed under upper bulkhead to increase visibility of tenant sign panels.

Light bulbs are to be removed above internally illuminated tenant signage that has been approved by Walmart

Lower wall portion is recessed 18"

Section Elevation



Front Elevation

- Upper bulkhead is painted brand blue to contain Walmart identity signage
Painted to match PANTONE 285C (SW 0285 Walmart Blue)
- Door to exit corridor (including door frame) to be painted dark gray to match SW 7664 Steely Gray
- Lower wall portion is recessed to create a second dimension for tenant signing on the 4th Wall
Painted SW 6519 Hinting Blue
- Ice machines are to be placed in two carved out niches at the 4th Wall
Ice machines are to be black with metal frames and handles (stainless steel or chrome may be used)

4th Wall Design (Remodel)

The alternative 4th Wall design should be used when the extended brand bulkhead is not achievable, as in the case of certain retrofit stores. Tenant signage and storefronts are flush with the bulkhead, but a paint reveal should be implemented to provide clear differentiation between the two zones and a natural barrier for both paint colors.

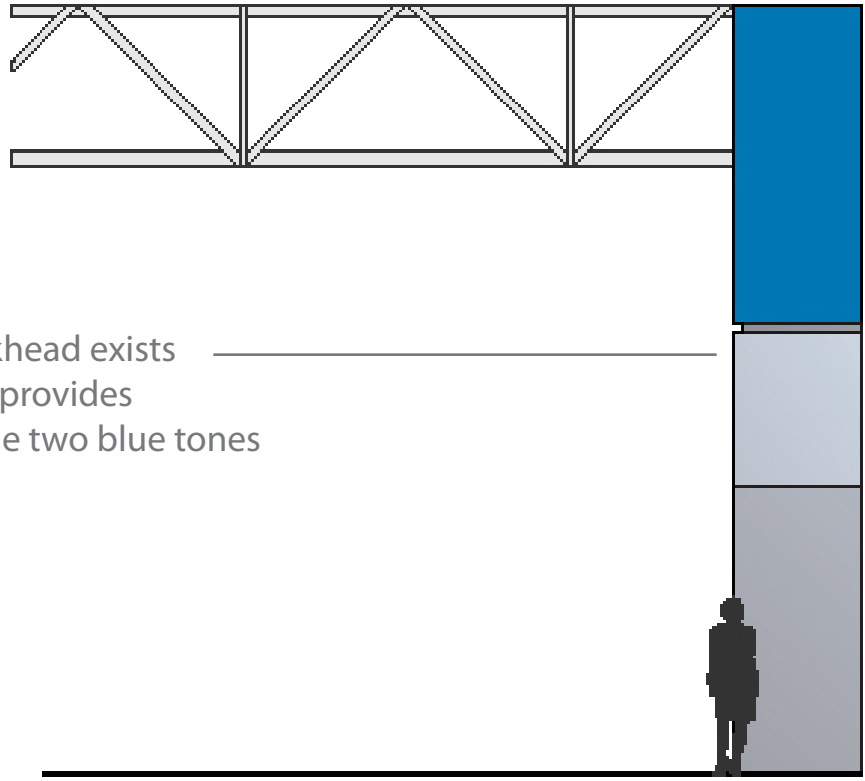

When an upper bulkhead exists a paint reveal detail provides a logical break for the two blue tones

Section Elevation



Front Elevation

Upper bulkhead is painted brand blue to contain Walmart identity signage

Painted to match PANTONE 285C (SW 0285 Walmart Blue)

Door to exit corridor (including door frame) to be painted dark gray to match SW 7664 Steely Gray

Lower wall portion is flush with upper brand wall

Painted SW 6519 Hinting Blue

Ice machines are to be placed in two carved out niches at the 4th Wall

Ice machines are to be black with metal frames and handles (stainless steel or chrome may be used)

Tenant Sign Panels: Optimal size

All tenant signage is to be placed on an individual sign panel supplied by Walmart that complies with the size, shape, and material requirements defined here.

Walmart leasing will specify the width of your sign based on width of your tenant space 90 days prior to possession. For Walmart approved customer signs with LED lighting, please work with your Walmart leasing representative to coordinate fabrication of your backer panel with installation of the LED signage. The backer panel is supplied and installed by Walmart. Walmart will specify sign fabricators for the backer panel by store location.

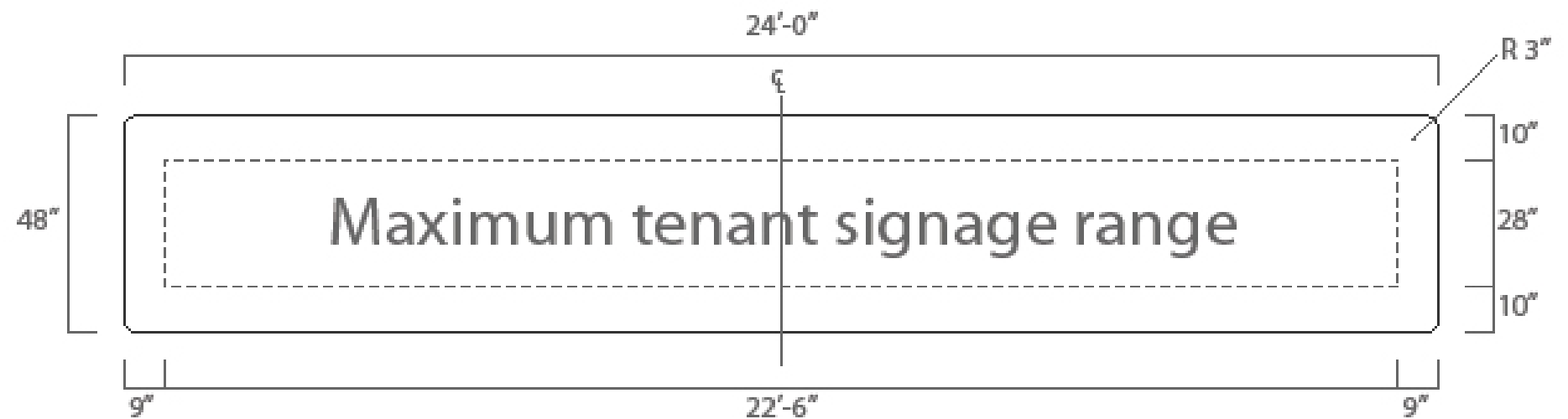

Sign Panel Detail

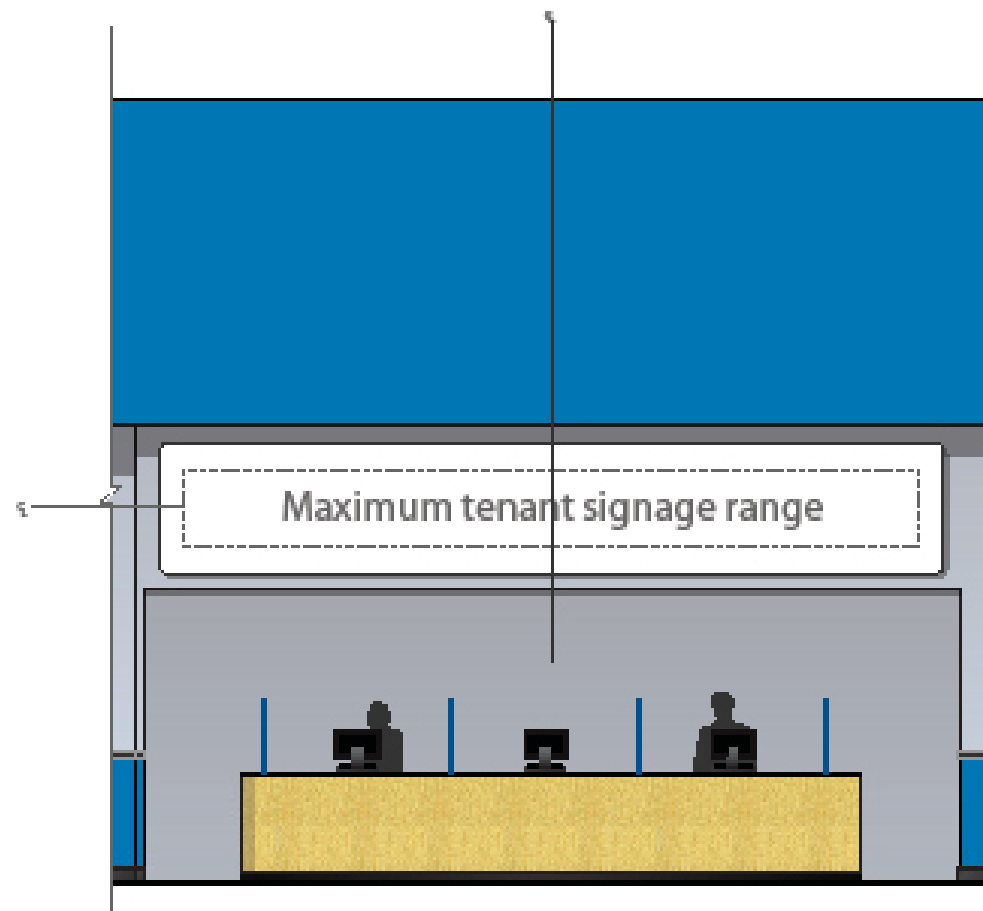

Front Elevation Detail

Optimal sign panels should be exactly 48" in height and are not to exceed 24'-0" in length*

Walmart to install sign panel vertically centered between the top of the tenant entry and the bottom of the brand blue bulkhead

Walmart to install sign panel centered horizontally based on tenant storefront opening

The sign panel is required to be 24" less than lease space and cannot exceed 12" in width of opening if opening is less than lease space

* Please refer to pages 17 through 19 for specifications of signs less than 48" in height.

Tenant Sign Panels: Additional Sizes

Based on existing bulkheads or other size considerations, Walmart will determine possible alterations of size and scale of tenants signs to fit the available space. In these instances, Walmart will notify the tenant of required sign panel size to fit tenant space and/ or sign letters in that specific store location.

Modified signs may be 20'-0", 16'-0", 12'-0" or 8'-0" in length, as specified here. Walmart will specify the largest sign size possible for your specific application. All sign panels must maintain a height of 48" when possible. Please refer to pages 17 through 19 for specifications of signs less than 48" in height.

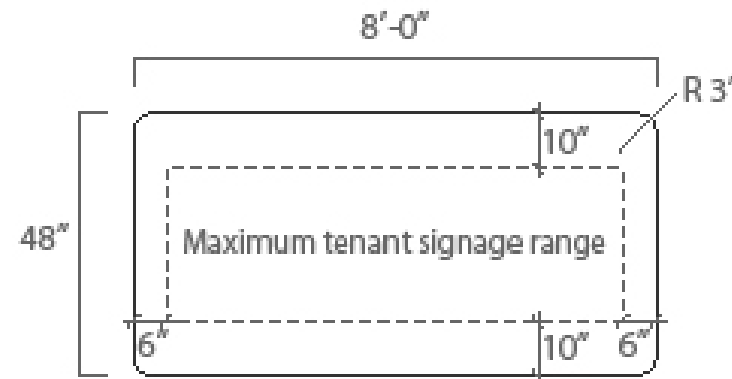
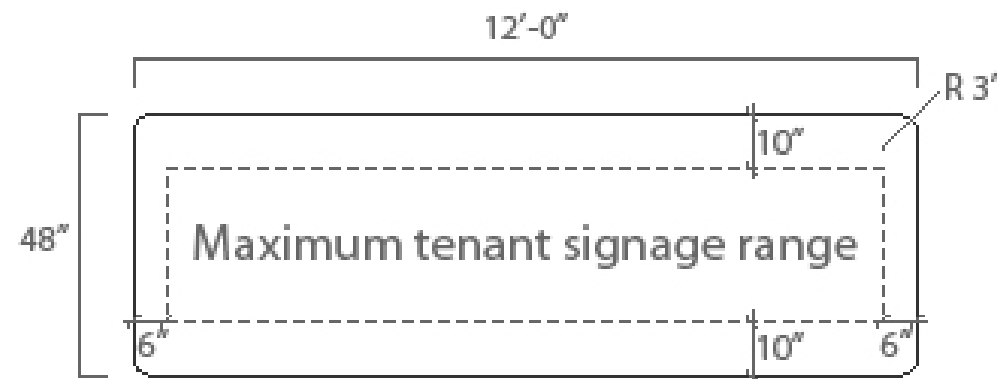

Additional Sign Panels

Tenant Sign Panels: Branded Sign Panels

Your brand is important to our customers, and recognizable logos can act as helpful wayfinding elements in the store. Brands that are approved by Walmart may use their own color palette for their logo and background sign panel. The size and shape of the sign panel must adhere to the guidelines set forth in this document, including corner conditions.

Any variations in 4th Wall signage by brands must be reviewed and approved by Walmart prior to implementation. This includes internally illuminated signage construction, which must use internal LED lamps.

Please refer to page 5 of this document for alternate panel sizes for branded signs.



Branded Sign Panels

Tenant Sign Panels: 4th Wall Restrictions

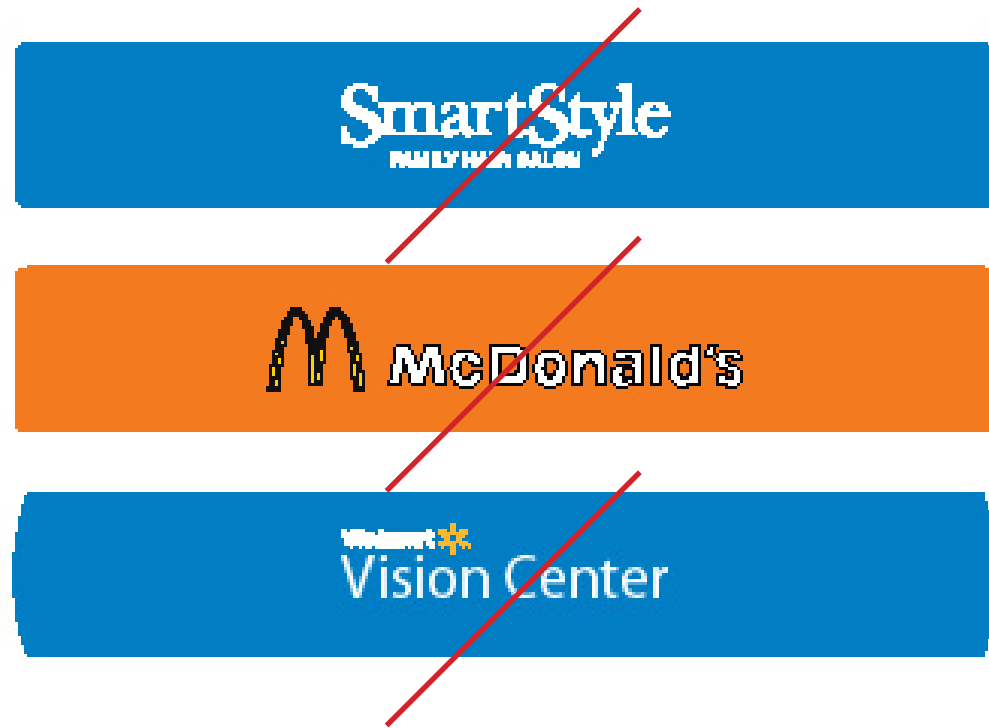

Do not use brand blue (PANTONE 285C) for sign panels unless it is a designated Walmart service

Do not use unassociated and unrecognizable color palettes for the treatment of approved national brands

Do not alter the holding shape of the sign panel



Do not alter type treatments and sizing for Walmart service signs

The following types of signs or sign components are strictly prohibited:

- Thermoformed or injection molded plastic signs or letters
- Animated, flashing, blinking, moving, rotating, or audible signs
- Pole signs
- Portable signs
- Signs made of paper, fabric, or flexible plastic
- Credit card signs or symbols
- Polished finishes on sign faces
- Exposed electrical raceways
- Any other type of signage or graphics deemed unsuitable by Walmart
- Tenants advertising must stay within the tenants lease space

Tenant Sign Panels: Walmart Services

All services that are brought to our customers by the Walmart brand must use the Myriad Pro typeface in white and be presented in the approved lockups as shown in this document.

Walmart services lock-ups may differ from the maximum tenant signage specifications found on pages 4 and 5 of this document.

Alternate sign panel sizes and lock-ups for Customer Service, MoneyCenter, Vision Center, and the Clinic are located on pages 9 through 16 of this document.

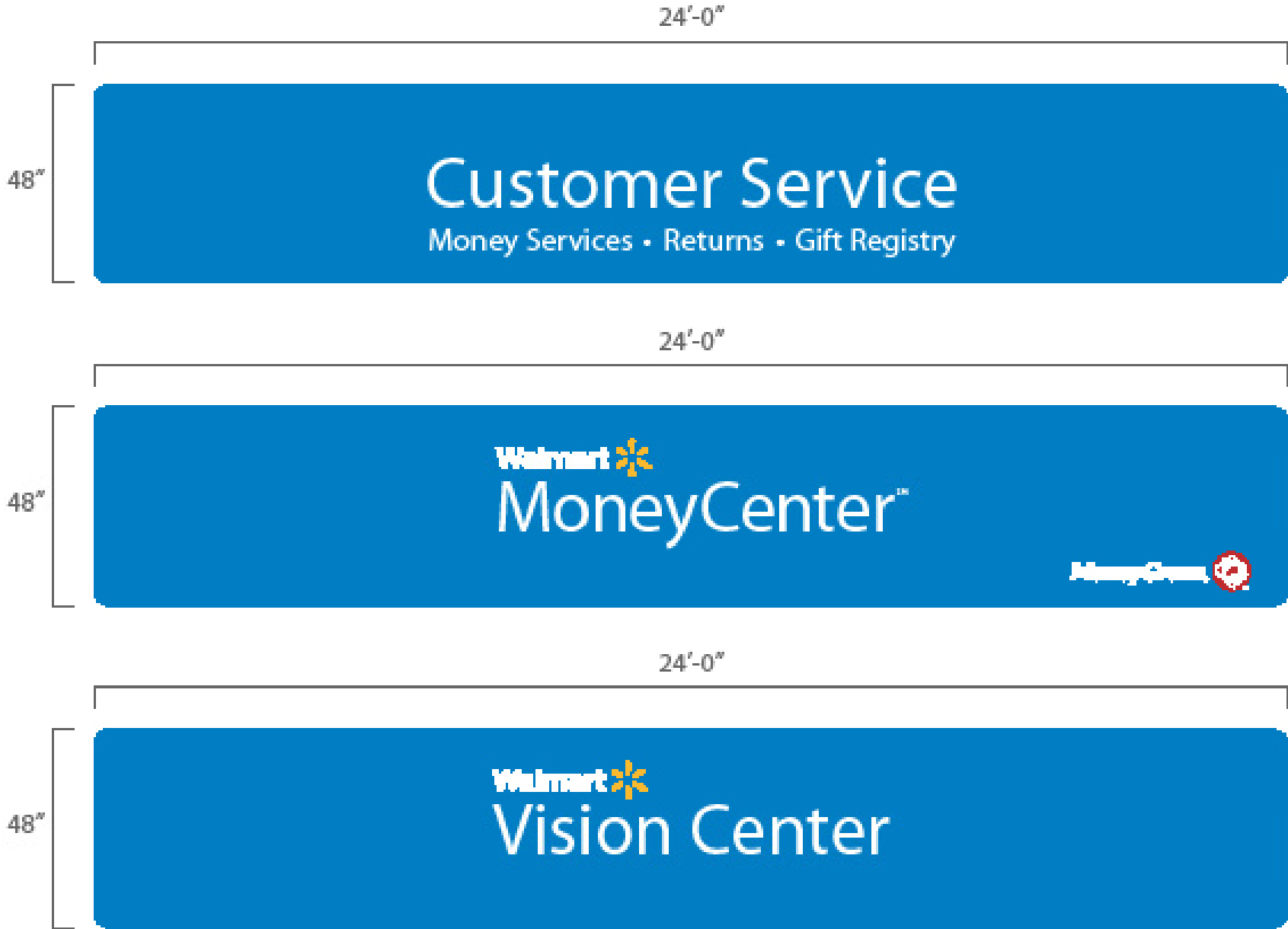

Walmart Service Sign Panels

Sign panels to match PANTONE 285C (SW 0285 Walmart Blue)

Tenant Sign Panels: Customer Service

Please refer to these specifications when alternate-size signage panels are needed for Customer Service.

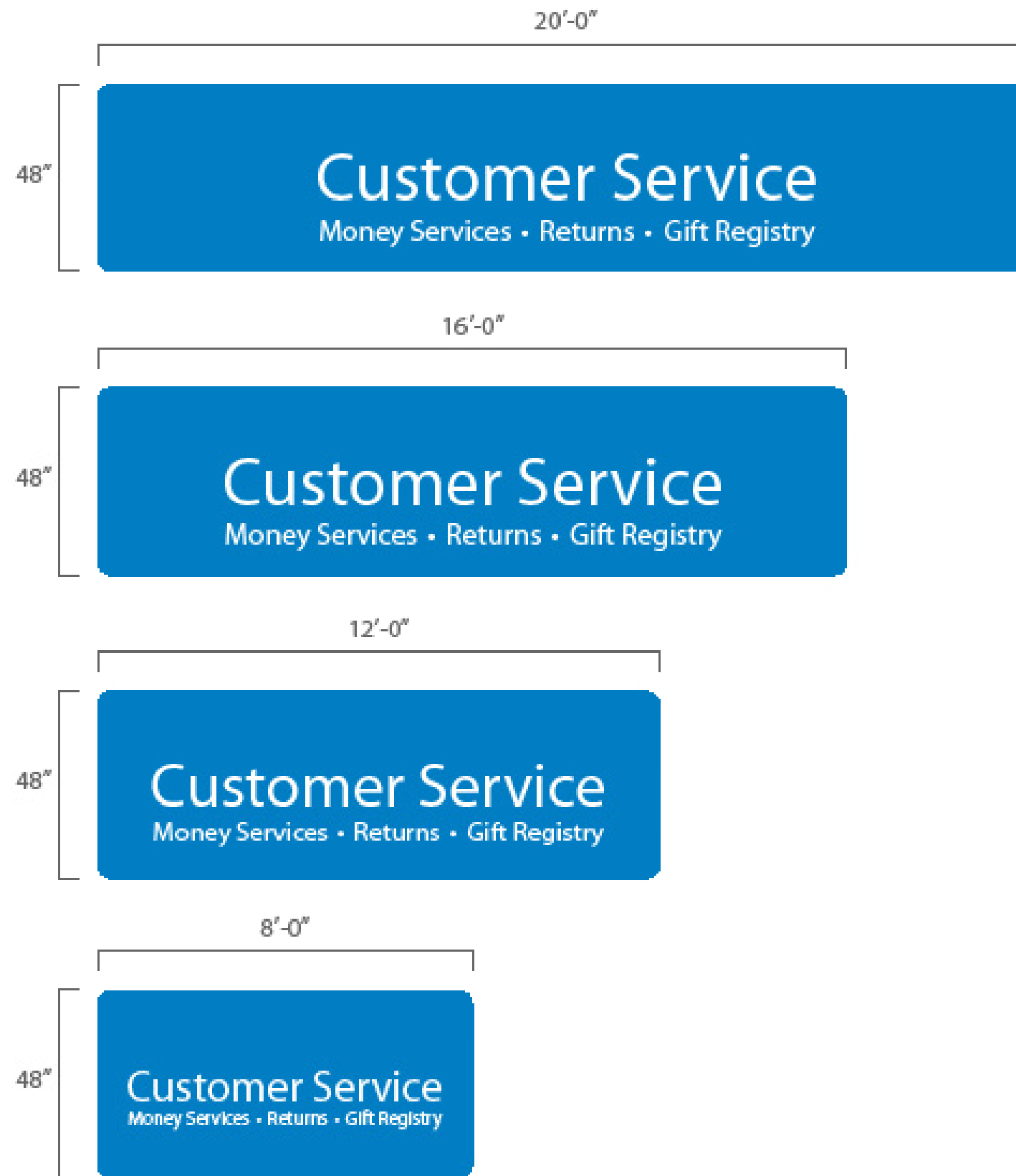

Customer Service Sign Panels

Tenant Sign Panels: Customer Service

In some stores Customer Service will occupy the same tenant space as both Site to Store and Photo Center at the 4th Wall.



Customer Service Sign Panel



Joint Site to Store / Photo Center Sign Panel



Customer Service shares tenant space with Site to Store and Photo Center



Tenant Sign Panels: Customer Service

Please refer to these specifications when alternate-size signage panels are needed for joint Site to Store / Photo Center sign panels.



Joint Site to Store / Photo Center Sign Panels

Tenant Sign Panels: MoneyCenter

Please refer to these specifications when alternate-size signage panels are needed for MoneyCenter.

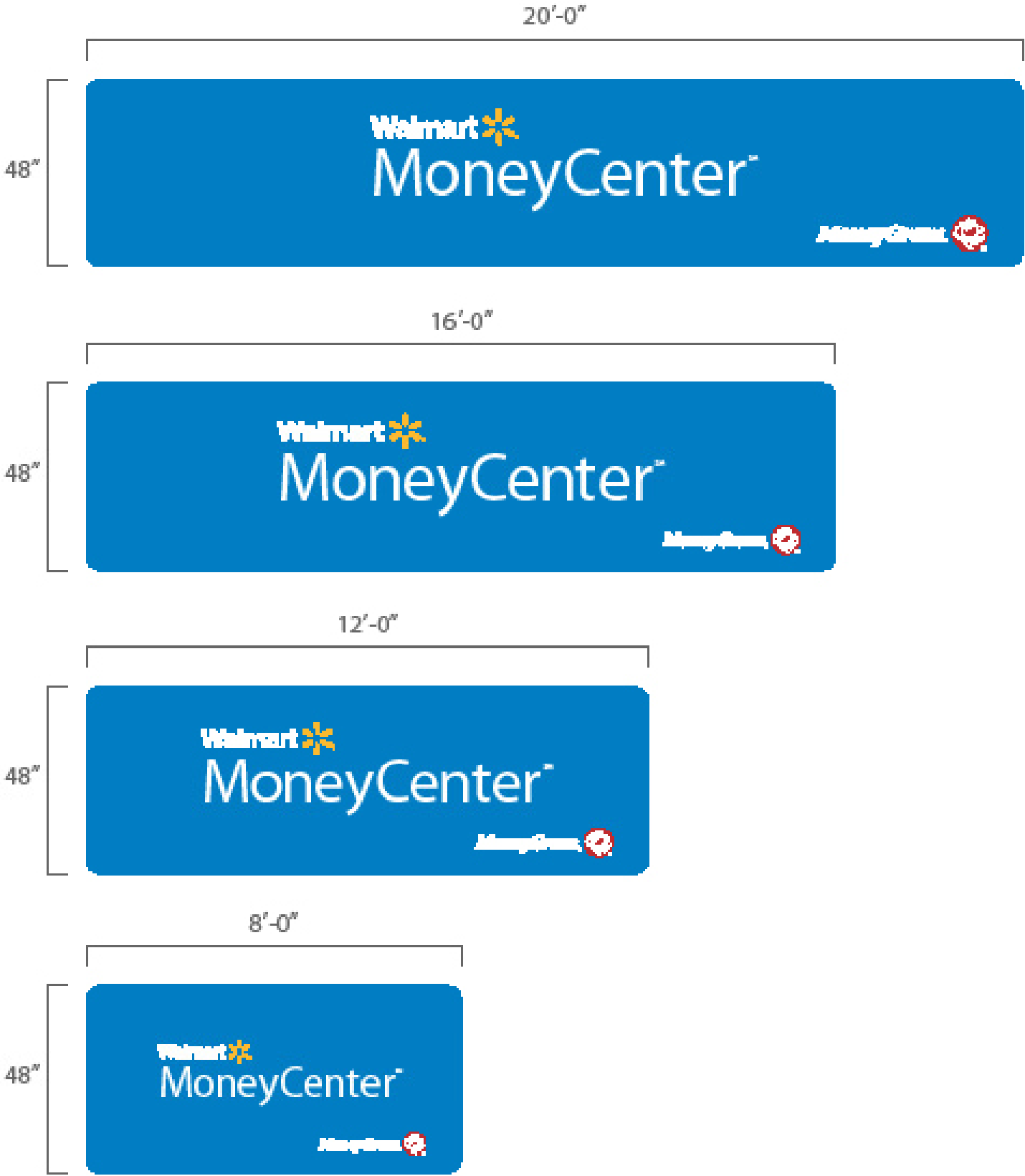

MoneyCenter Sign Panels

Tenant Sign Panels: Vision Center

Please refer to these specifications when alternate-size signage panels are needed for Vision Center.

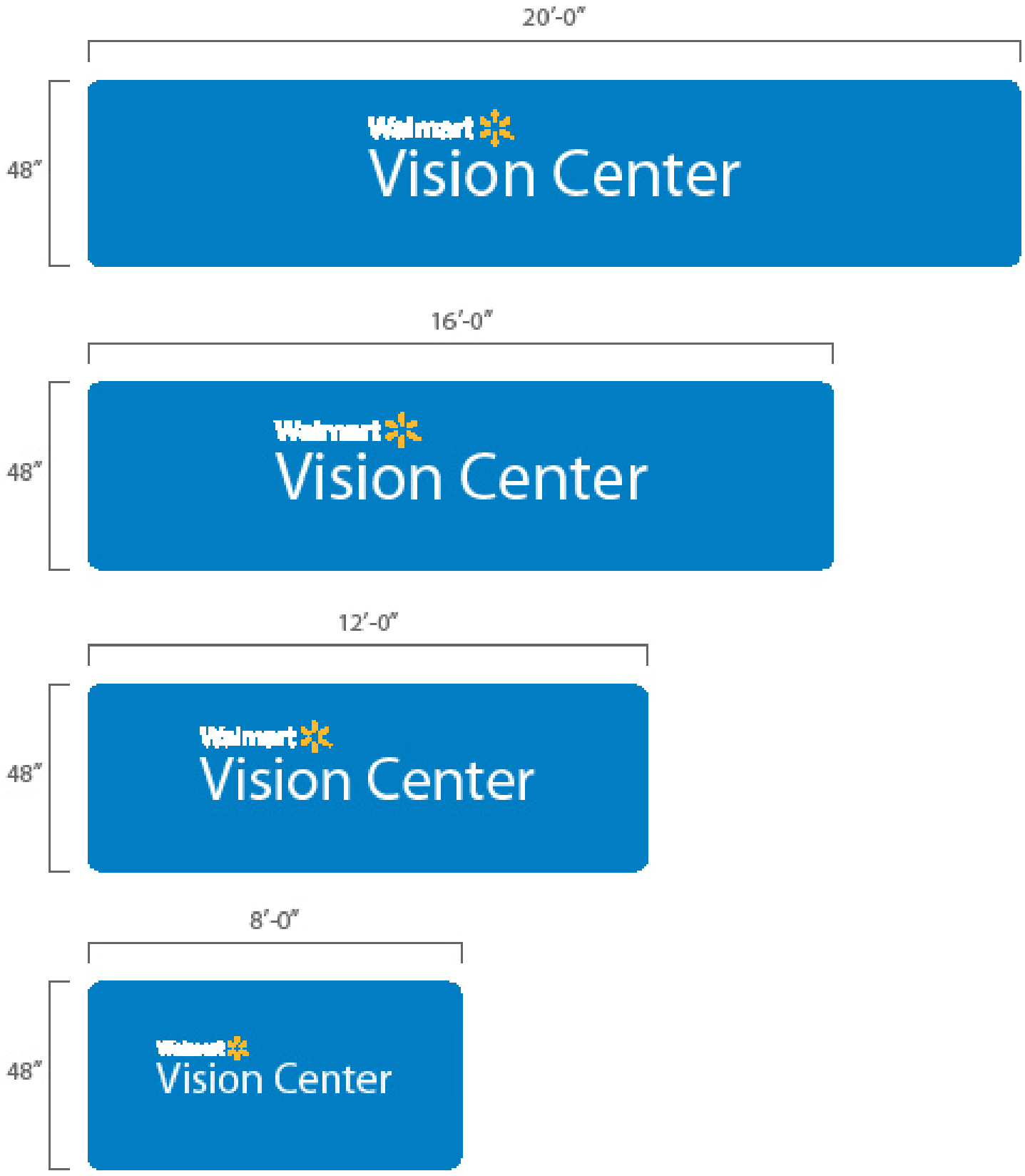

Vision Center Sign Panels

Tenant Sign Panels: Clinic Signage

The Clinic at Walmart signage should use the Myriad Pro typeface and be formatted in the approved lockup as shown here. Partner logos should appear in their own color palette on a neutral background panel (1/2" Brite White Ultraboard), along with "operated by" or "affiliated with" messaging, as appropriate.

Clinic lock-ups may differ from the maximum tenant signage specifications found on pages 4 and 5 of this document.

Alternate sign panel sizes and lock-ups for The Clinic are located on pages 15 and 16 of this document.

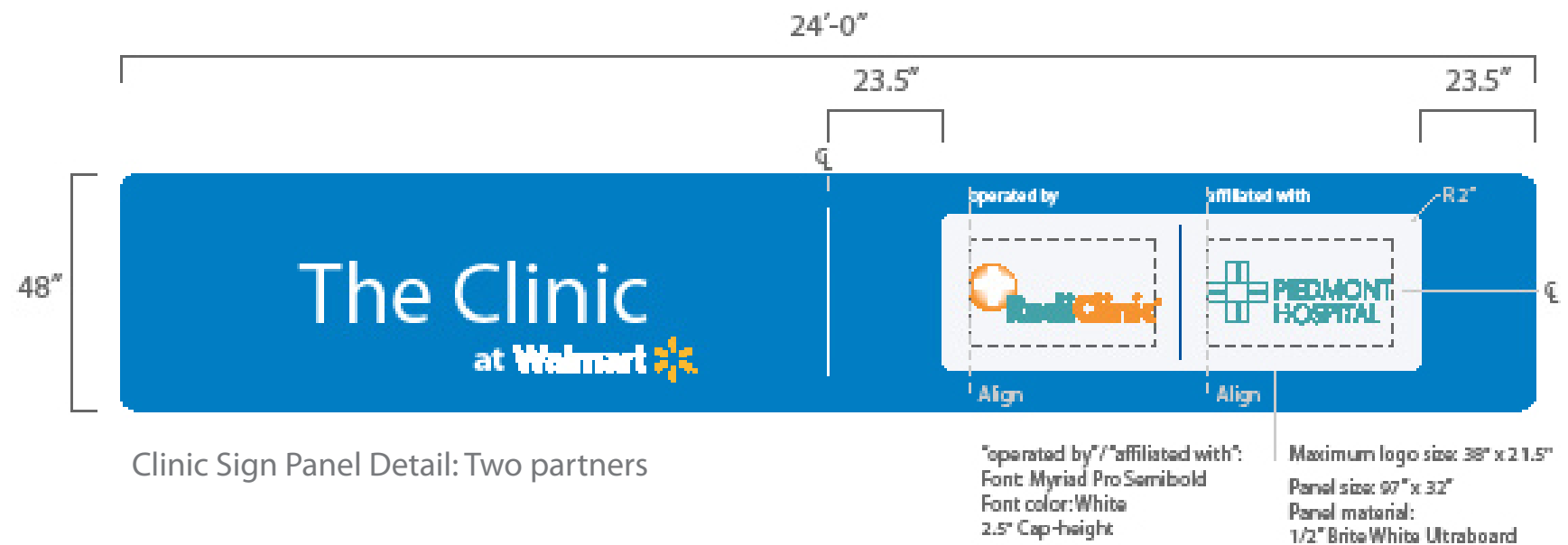
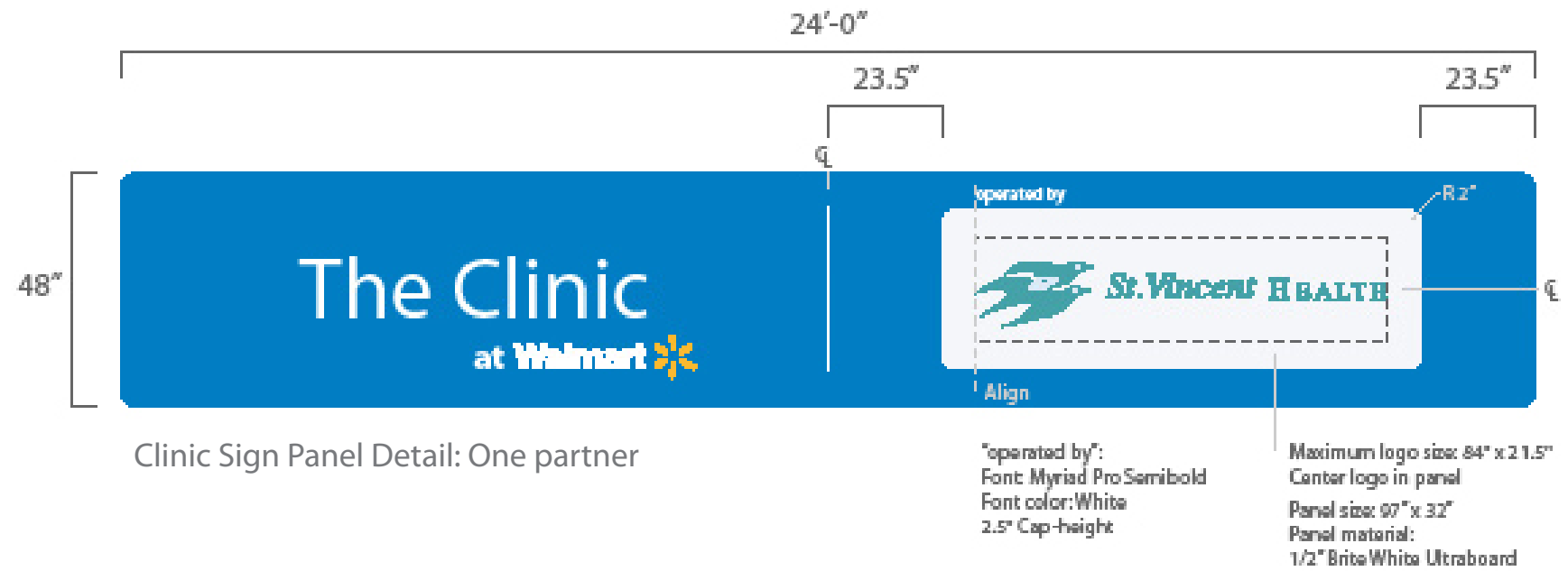

Sign panels are painted to match PANTONE 285C (SW 0285 Walmart Blue)

Tenant Sign Panels: Clinic Signage (Single Partner)

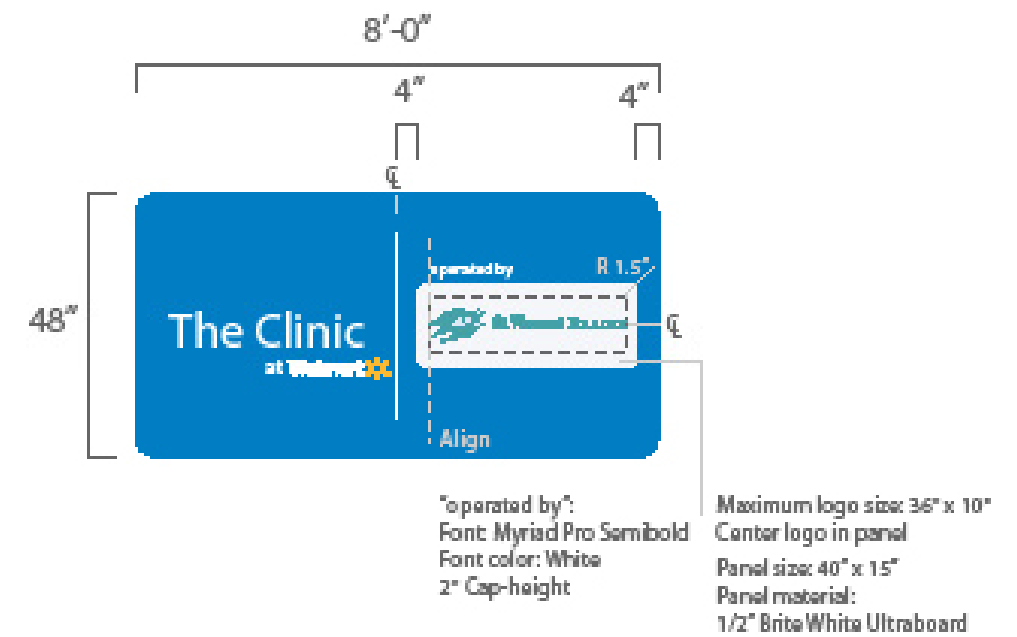
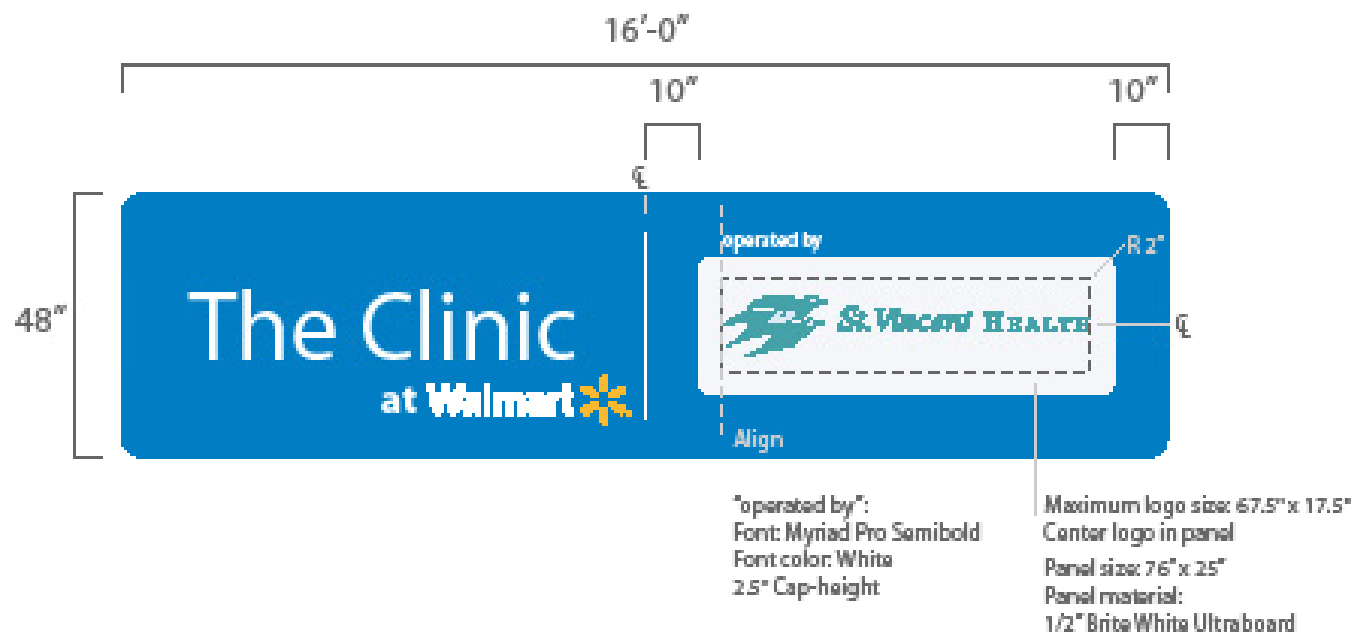
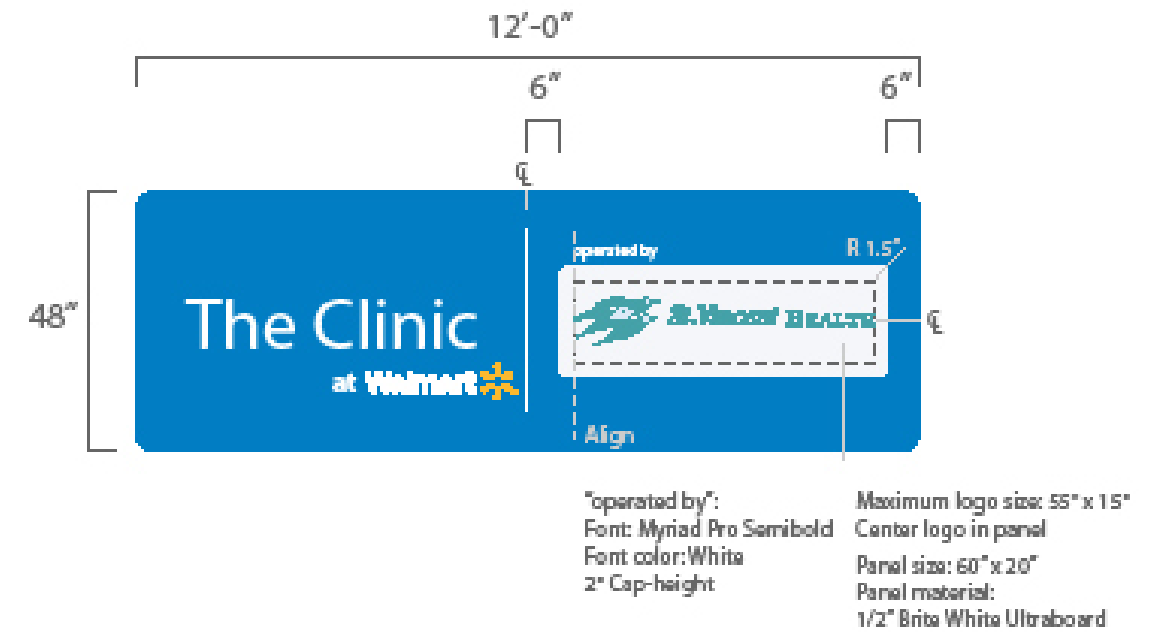
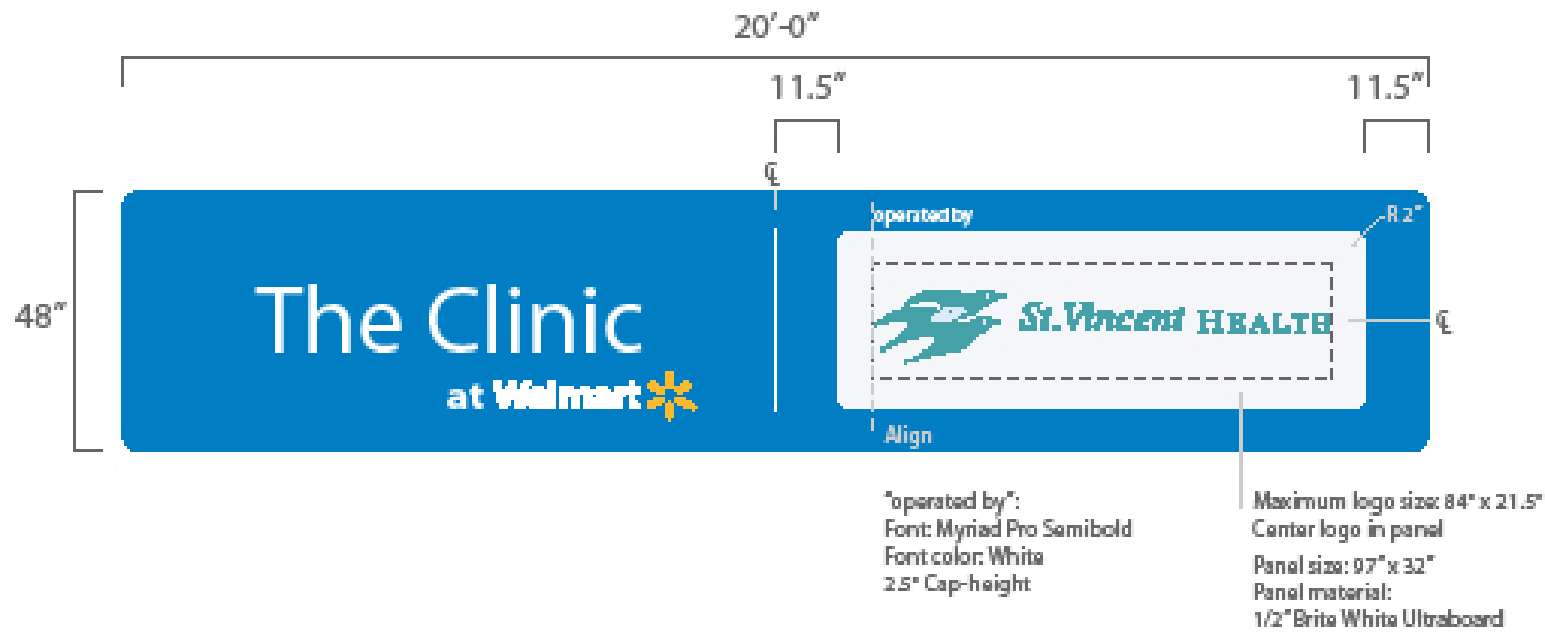

Tenant Sign Panels: Clinic Signage (Dual Partners)

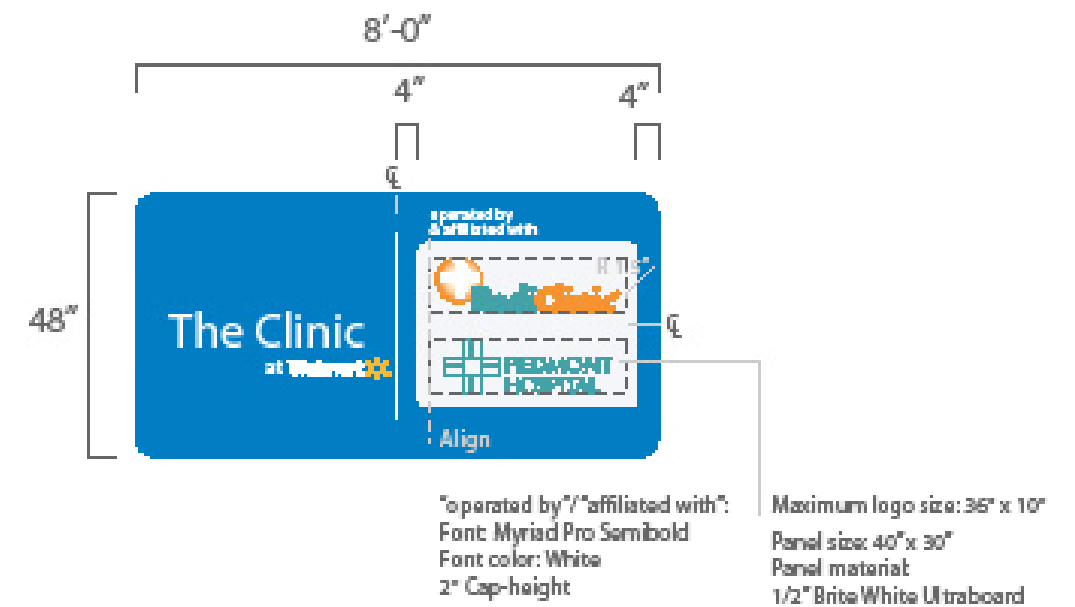
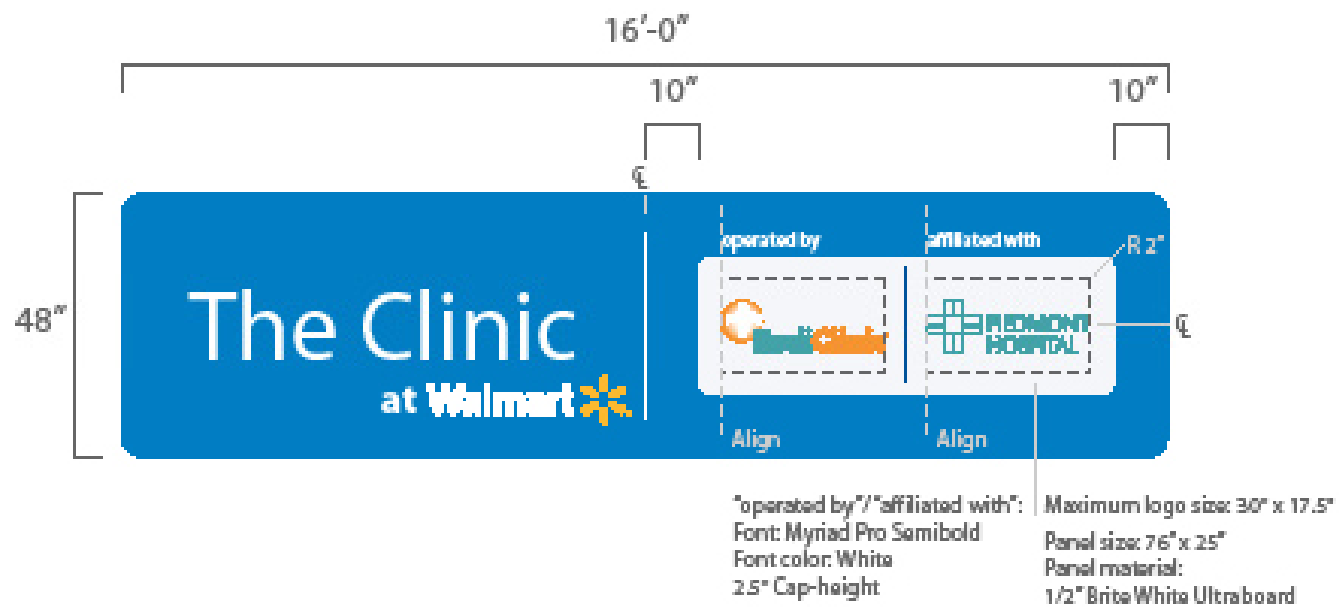
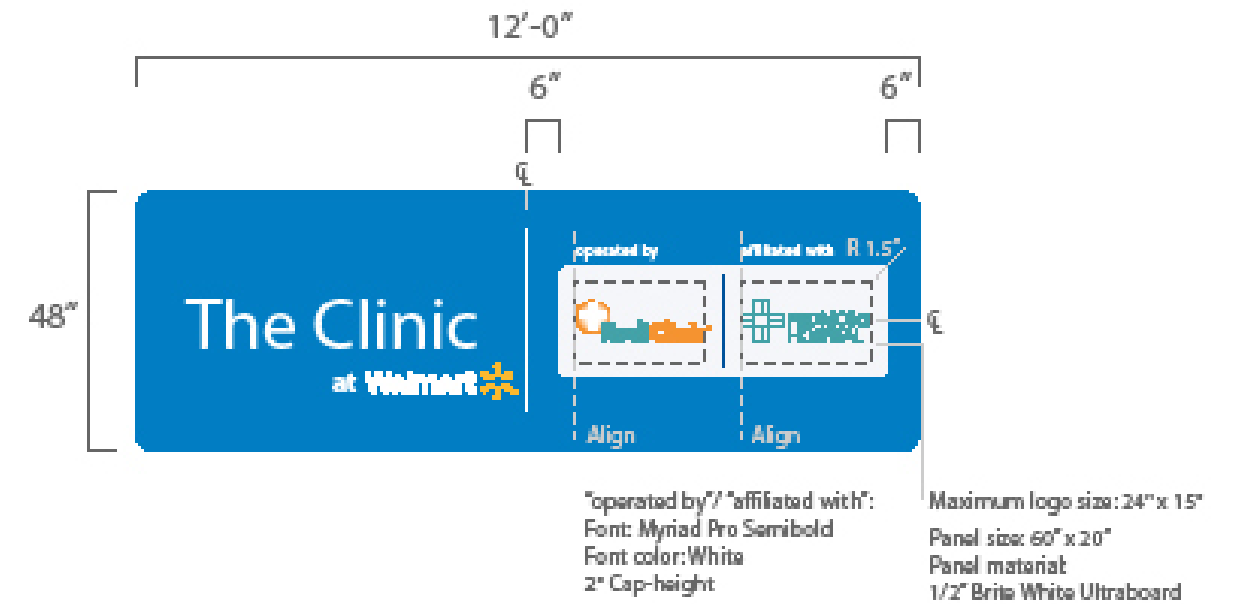

Tenant Sign Panels: Lowered Ceiling Height

Some stores may have a lower than average ceiling height, and therefore less space available for tenant signs. When less than 5'-0" is available for signage, use the revised panel shown here, with a height of 30" for all tenants and Walmart services. The optimal length for these sign types is 20'-0". Modified signs may be 16'-0", 12'-0" or 8'-0" in length.

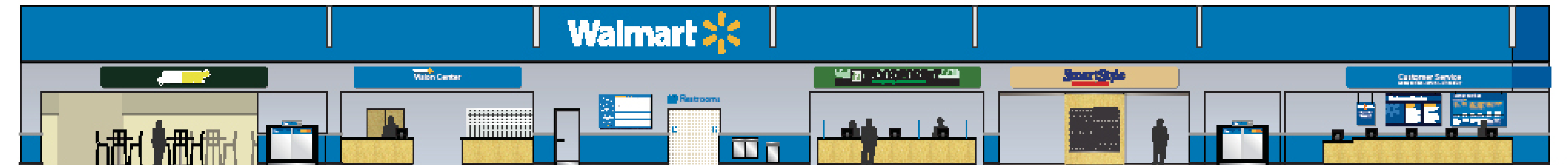
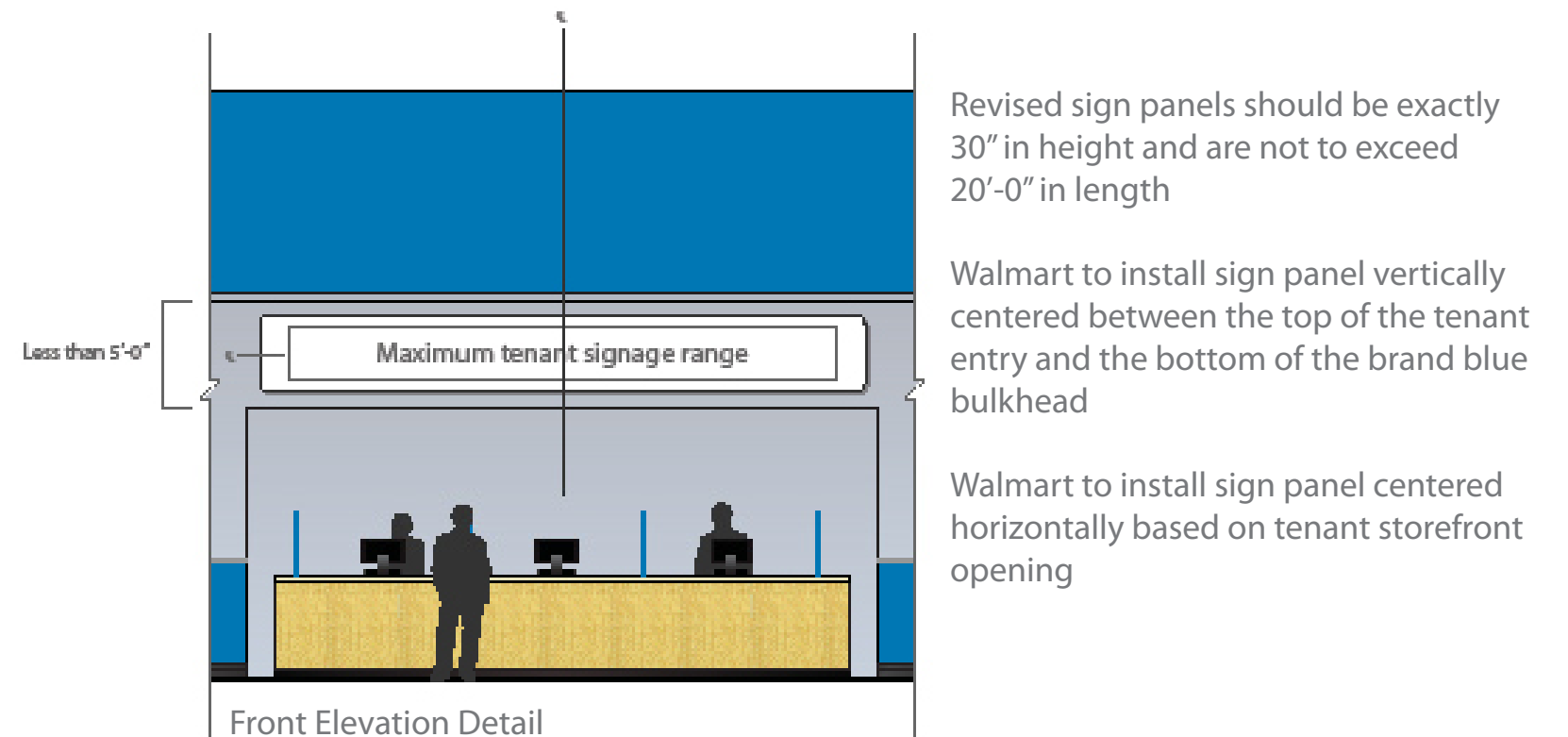
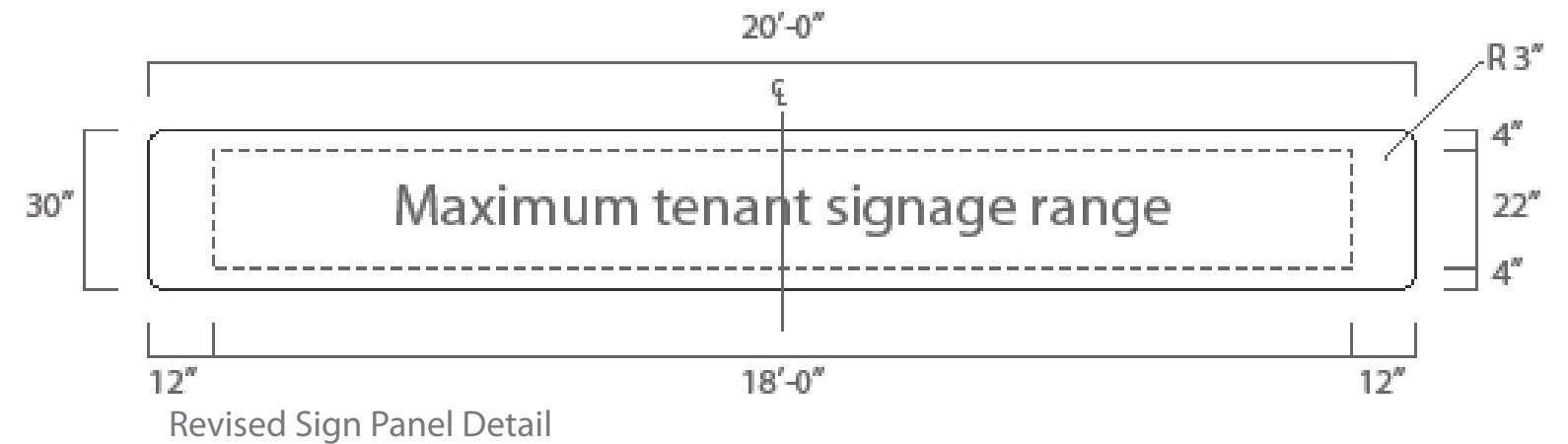

Front Elevation

Tenant Sign Panels: Lowered Ceiling Height (Branded Sign Panels)

Please refer to the specifications on pages 18 and 19 for branded and service sign panels that are reduced to 30" in height.



Revised Branded Sign Panels

Tenant Sign Panels: Lowered Ceiling Height (Walmart Services)

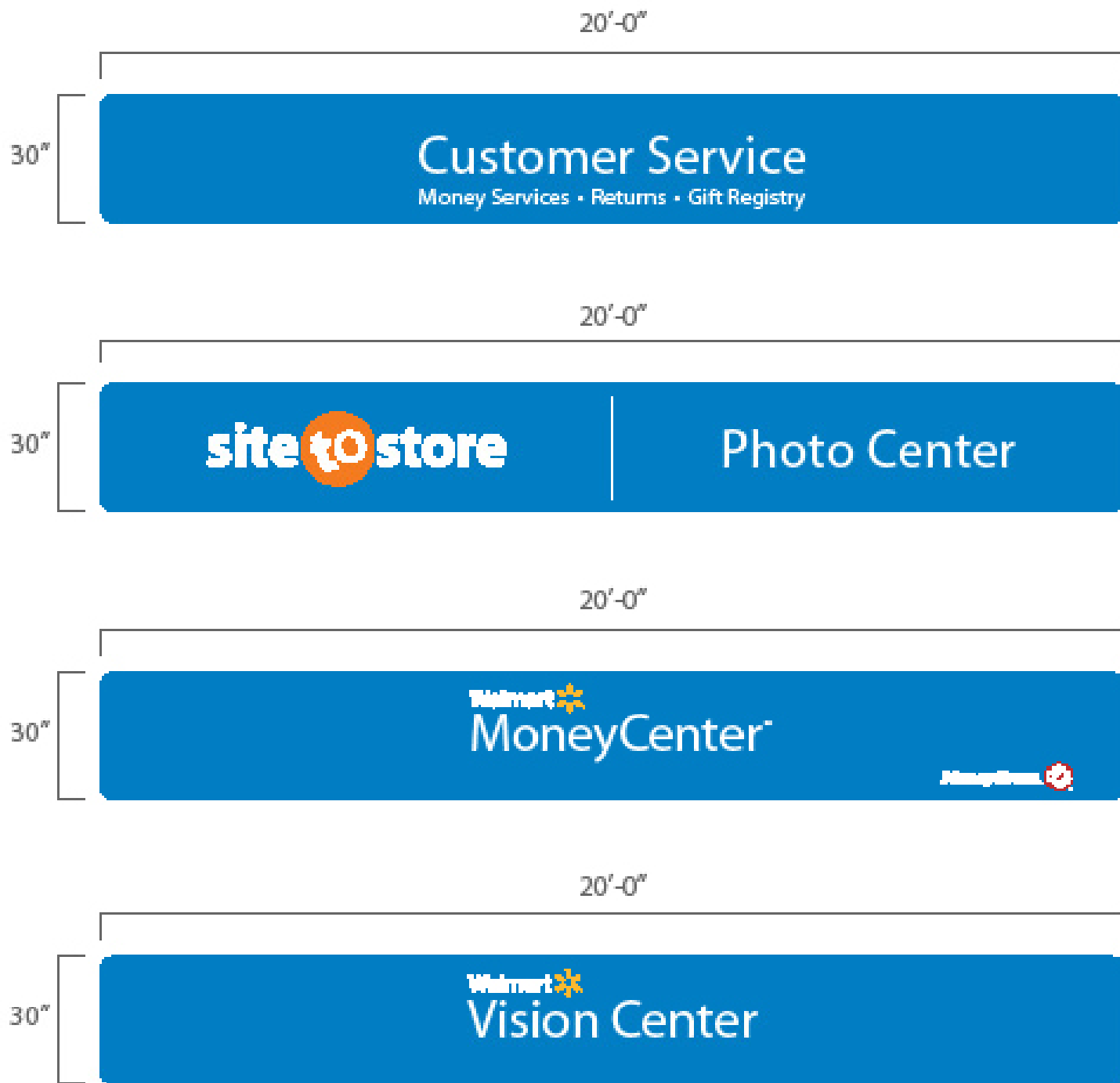

Revised Walmart Service Sign Panels

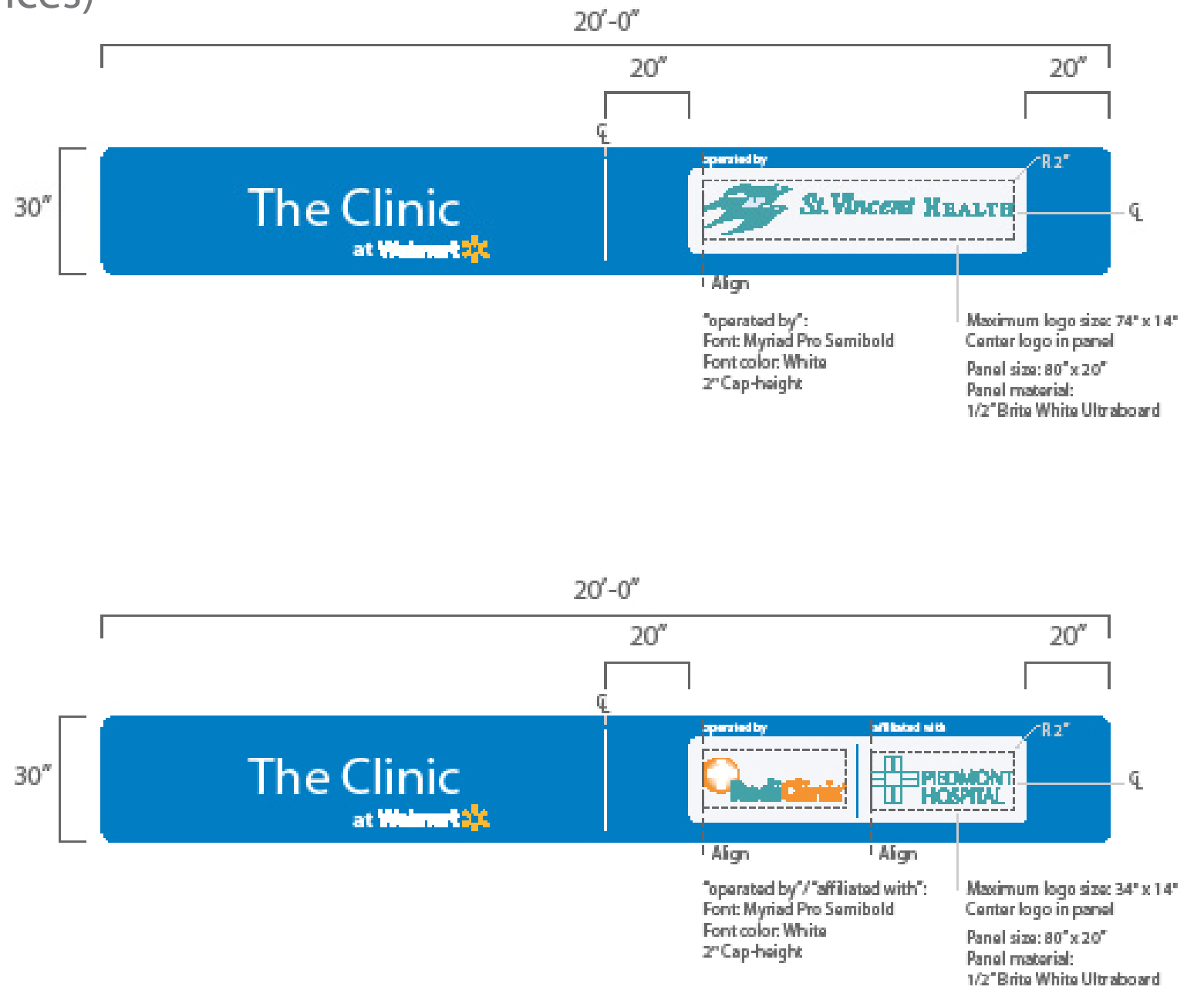

Tenant Sign Panels: Awnings

Certain food service tenants may use awnings to sign their spaces. Brands that are approved by Walmart may use their own color palette for their logo and awnings. The size and shape of the awnings must adhere to the guidelines set forth in this document.

Any variations in 4th Wall signage by national brands must be reviewed and approved by Walmart prior to implementation. This includes internally illuminated signage construction, which must use internal LED lamps.

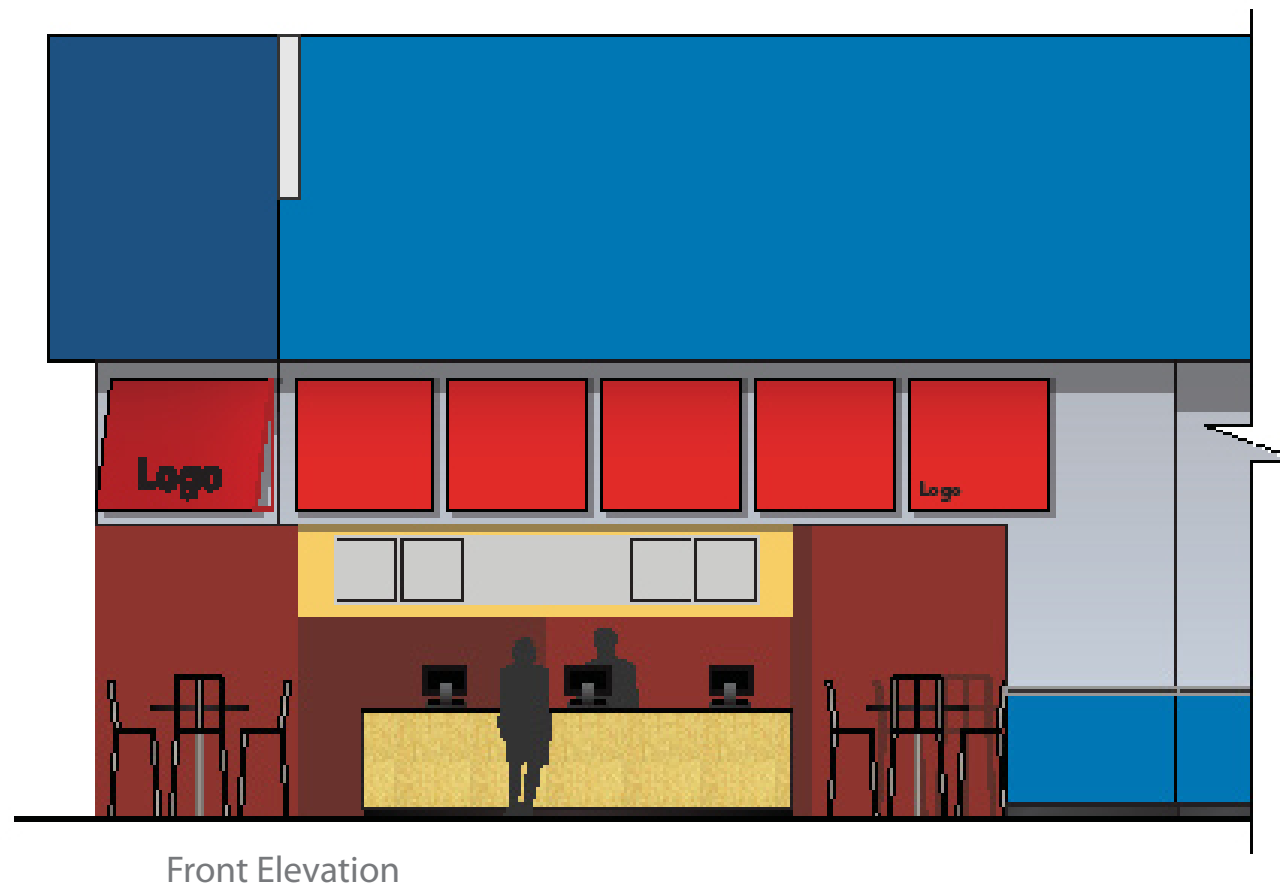

Awnings should be evenly spaced and should span the entire width of the tenant space

Awnings should not all contain the brand logo or icon

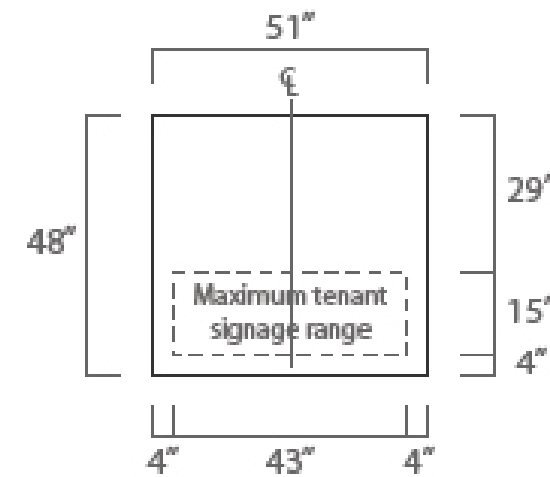

Full Logo Awning Detail

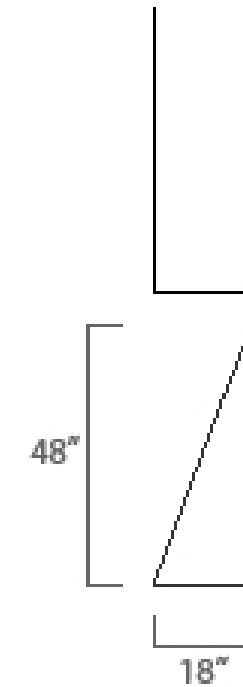

Awning Section

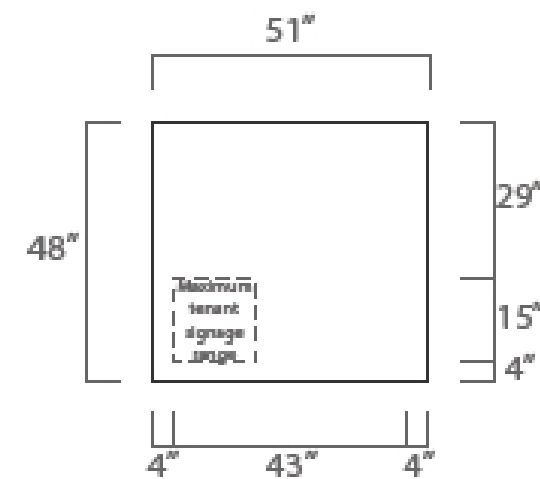

Icon Awning Detail

When using an icon or symbol align art in the bottom left corner of the awning

Use icons on awnings on the far ends of the tenant space

Fabrication & Installation

The following construction and fabrication guidelines apply to all signage and identifying graphics:

All tenant signage materials and fabrication methods must be approved by Walmart in writing prior to manufacturing and installation.

All signs must be fabricated and installed using the highest quality workmanship, materials, and components, and shall comply with all industry standards, building codes and all other applicable codes.

All plastic materials must have a matte finish to limit glare.

All rigid signage materials must be of sufficient thickness to prevent warping or bending.

Installation methods for all signage elements must be indicated in shop drawings and approved by Walmart prior to installation.

If illuminated signage has been approved by Walmart lighting methods are to be limited to internal LED lamps. Thickness of illuminated signs should be no deeper than 4". There should be no visible fasteners or framing on faces of lit signs.

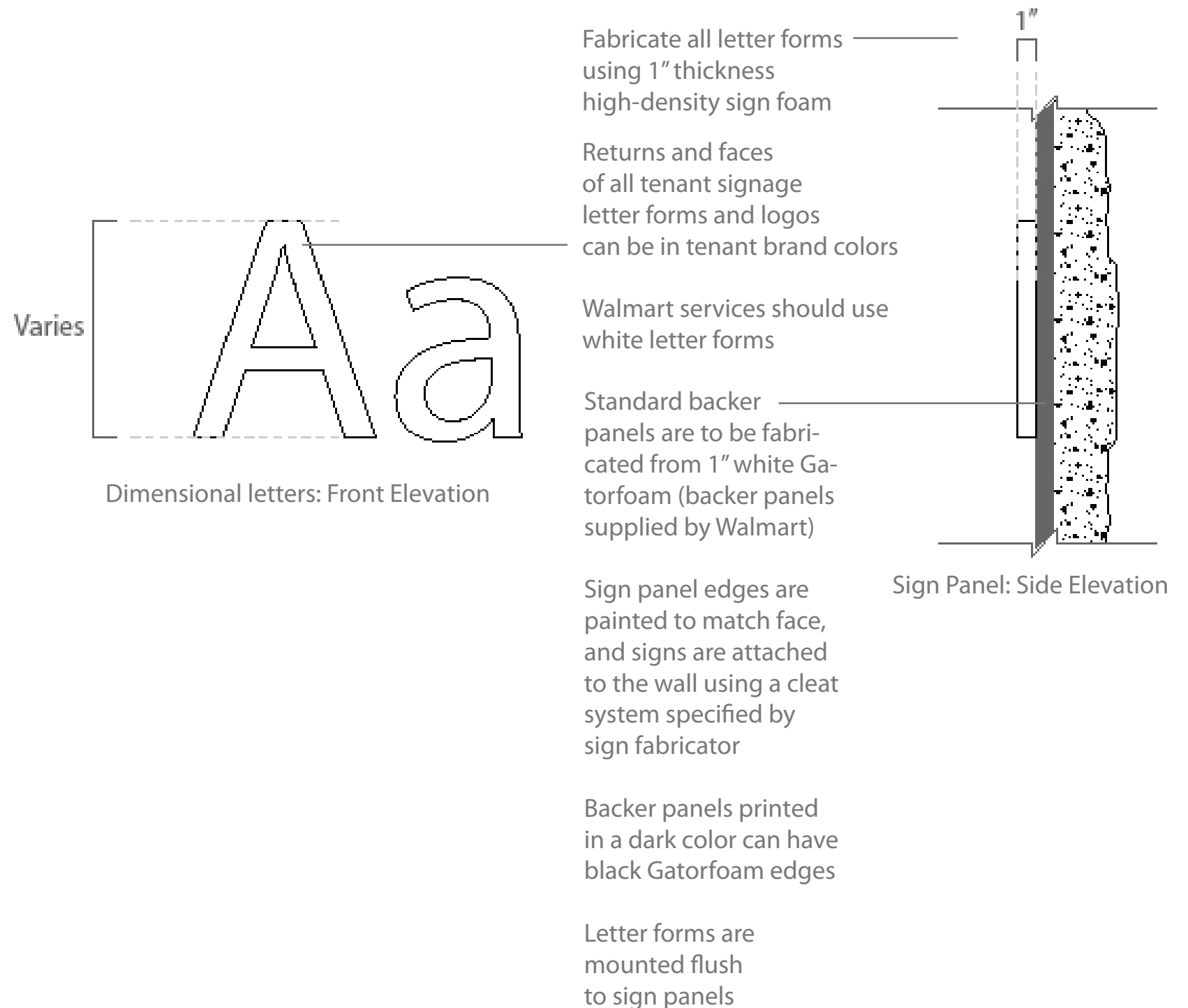

Restroom Signage

General restroom signage, as well as male and female indications, should adhere to the following set of guidelines.

Restroom signage lettering is to use the Myriad Pro typeface to match PANTONE 285C

Missing Children's Board placement

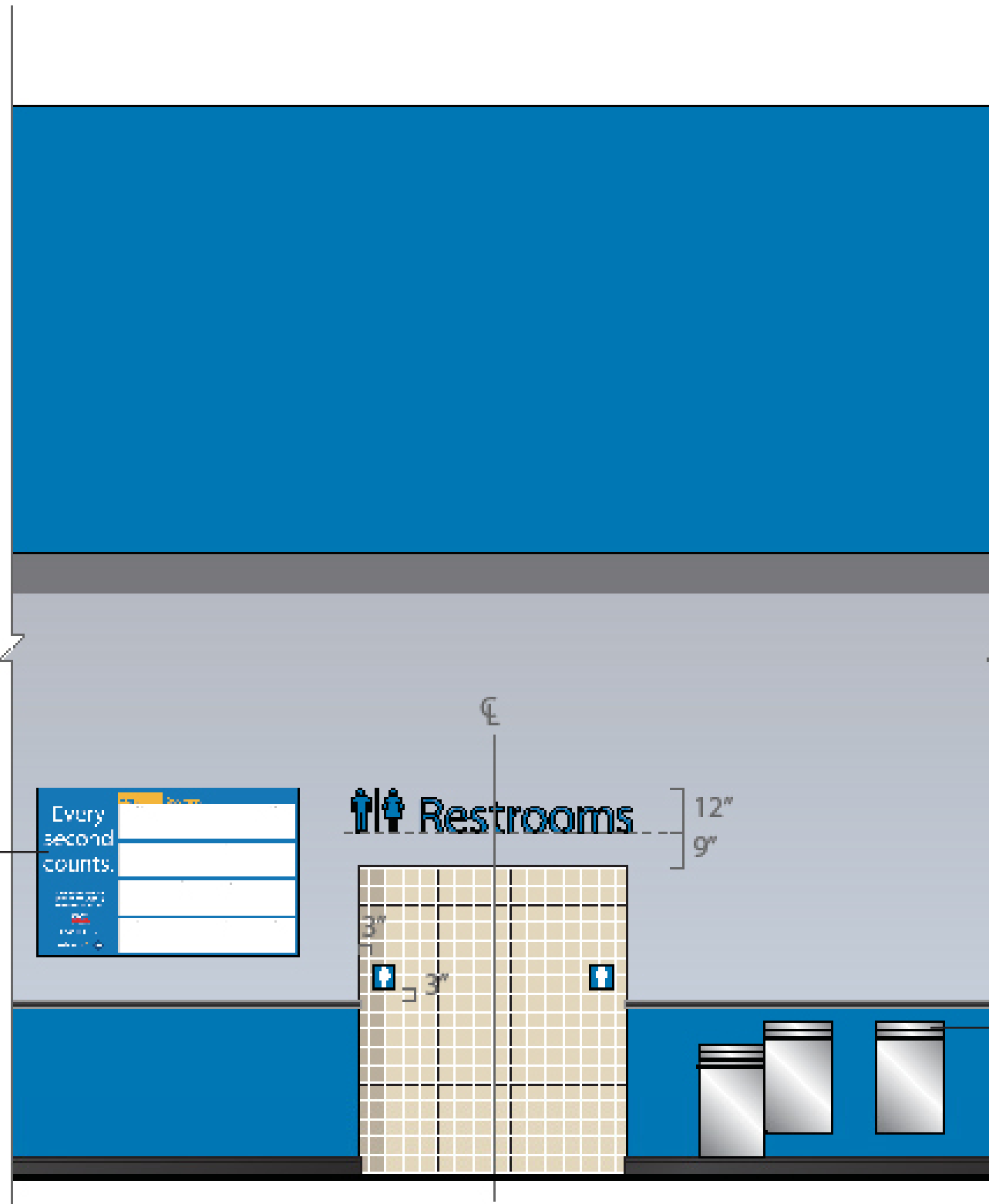

Restroom Elevation

6"
6"
Water Coolers in Stainless Steel finish

Contacts

For sign art questions or to submit sign renderings for review please contact the following individuals:

Steve Rogers
Senior Director, In-Store Presentation
Customer Experience Division
Phone: 479.204.8457
E-mail: steve.rogers@Walmart.com

Judy Lapp
Senior Project Manager
New Business Development
Phone: 479.273.4421
E-mail: judy.lapp@Walmart.com

Gary Withrow
Senior Director Leasing Operations
New Business Development
Phone: 479.277.9433
E-mail: gary.withrow@Walmart.com

Erin Baker
Production Manager
In Store Presentation
Phone: 479.277.9871
E-mail: erin.baker@Walmart.com

One of the following sign fabricators will be specified by Walmart for use on 4th Wall signing elements based on store location:

Miller Zell, Inc.
Contact: Paul Papantonis
Phone: 404.526.1467
Fax: 404.526.1391
E-mail: paul.papantonis@mzretailservices.com
Website: www.millerzell.com

Pratt Corporation
Contact: Sunny Baker
Phone: 317.524.3285
Fax: 317.524.1903
E-mail: sbaker@prattcorp.com

Advance Graphic Systems
Contact: John Hall
Phone: 248.656.8000
E-mail: johnhall@advancegraphic.net

O’Ryan Group
Contact: Barbara Hale
Phone: 901.794.4610
Fax: 901.794.3206
E-mail: bhale@oryangroup.com